

Instructions by Time4Sleep Products

Sophia Pink Ottoman Bed Frame

Assembly instructions for Sophia Pink Ottoman Bed Frame by Time4Sleep

Product Information

Sophia Pink Ottoman Bed Frame

Description

The Sophia Ottoman Bed Frame combines elegance and practicality with its soft pink upholstered design. Its clean lines create a timeless centerpiece. The sturdy slatted base ensures long-lasting mattress support while enhancing comfort. Designed with a front-lift ottoman mechanism, the bed provides generous underbed storage, easily accessible with a fabric pull handle. Perfect for maximizing bedroom space, the Sophia Ottoman Bed Frame blends style, comfort, and smart functionality.

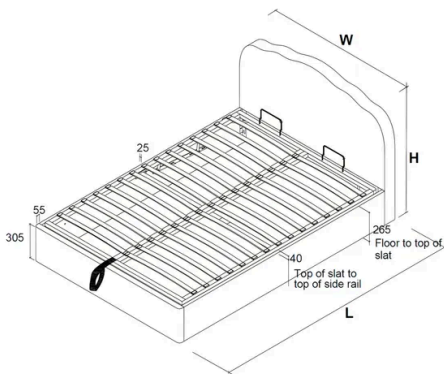

Product specifications

	Double	King
Overall Dimensions (LWH mm)	2085 x 1475 x 1010	2185 x 1625 x 1010
Storage Dimensions (LWH mm)	1915 x 1370 x 230	2015 x 1520 x 230
Distance between slats (mm)	70	70
Slat Dimension (mm)	670 x 53 x 9.5	745 x 53 x 9.5
Ottoman Piston Strength	800N	800N

SKU

Sophott46pink, Sophott50pink

Before you start



Instructions by Time4Sleep Products

Sophia Pink Ottoman Bed Frame

- Please read this sheet prior to assembly to familiarise yourself with the various stages of construction. Carefully open the pack supplied and check the contents against the parts and fittings check list.
- Do not destroy any of the packaging until you are certain that you have all the necessary parts for the assembly.
- Please ensure that the packaging is disposed of in a safe environmentally friendly way.
- **Caution:** There are small components used in the construction of this unit. These loose items should be kept away from young children during assembly, to avoid danger of choking.

Care & Maintenance

In the unlikely event of missing or damaged parts, please contact your retailer. Please have this guide at hand quoting the part code reference numbers shown when requesting spare or replacement parts.

General Hints & Tips

- Two person assembly
- Please retain your assembly instruction and tools provided for future use. Periodically check that all bolts are still tight.

Warnings



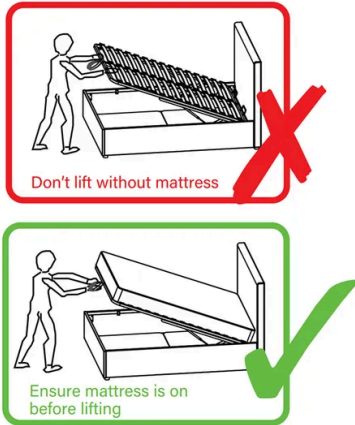

- **Note:** Before moving the frame, place the mattress on the slats.
- Without a mattress in place, the speed of movement is quick and may cause injury, so great care is needed.
- Carefully lower the frame with the fabric hand strap ensuring the sides are aligned with the side rails, there should be an even gap on each side. A quick tip in case you're having trouble. If the gaps between the sides of the frame aren't even, first make sure the bed is still square.
- If it is square try re-aligning the slat frame by loosening the six bolt sets, adjust the frame then retighten the bolts.
- Depending on the weight of the mattress, the rising speed will vary, so be careful until you get used to the speed.
- Always use the hand strap to lift or lower the frame - keep fingers well away from the moving parts.
- **When fully assembled and the mattress in position, please raise & lower the ottoman 4/5 times to ensure the gas pistons are fully lubricated.**
- You must ensure that the mattress is on the bed frame before operating the lift mechanism Failure to do so could result in injury.
- Keep hands clear of the mechanism when opening or closing the ottoman.
- Beware of entrapment – Never reach in through the mechanism to access the storage area.
- Always ensure that the ottoman is FULLY opened before accessing the storage area.
- Do not exceed the maximum weight as specified in the table below:

Safety

- Use caution when operating, always use the handle when lifting.
- Note: This bed uses a pressurised mechanism.
- To be operated by adults only.
- Please ensure that children and pets are kept away from the bed when operating the lift mechanism.
- Keep children and pets away from the storage area. Do not overload the internal storage base.
- Do not stand inside the internal storage area of the bed.
- Before removing the mattress secure the frame to ensure it does not open unexpectedly.
- Do not attempt to lie on the mattress when the ottoman is in the raised position.



Tools

A - Bolt (M8x25mm) 44 

B - Bolt (M8x35mm) 8 

C - Bolt (M8x50mm) 6 

D - Flanged Lock-Nut M8 10 

E - Spring Washer For M8 Bolts 6 

F - Flat Washer For M8 Bolts 6 

G - Corner Hook - Left 2 

H - Corner Hook- Right 2 

I - Allen Key for M8 Bolts 2 

J - Spanner for M8 Nuts 1 

K - Metal Connection Plates For The Slat Frame 2 



Parts

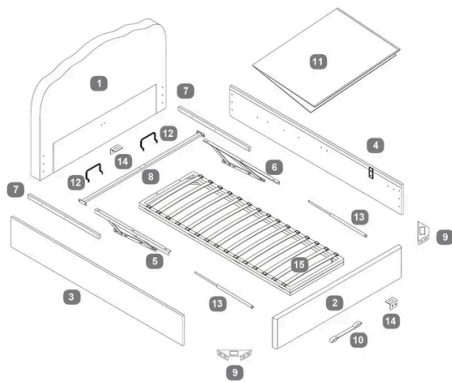

1	Headboard	1 piece(s)
2	Footboard	1 piece(s)
3	Side Rail - Left	1 piece(s)
4	Side Rail - Right	1 piece(s)
5	Gas-lift Mechanism - Left	1 piece(s)
6	Gas-lift Mechanism - Right	1 piece(s)
7	Spacer Rail For Gas Lift Mechanism	2 piece(s)
8	Side Rail Cross Bar	1 piece(s)
9	Angled Corner Bracket	2 piece(s)
10	Fabric Handle Strap	1 piece(s)
11	Fabric Base Cover	1 piece(s)
12	Mattress Stopper	2 piece(s)
13	Gas-lift Piston	2 piece(s)



14 'L' Shape Bracket 2 piece(s)

15 Metal Slat Frame 1 piece(s)



Steps (13)

1. Secure Corner Hooks to Side Rails

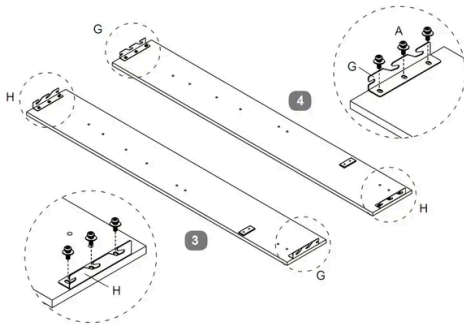

1. Attach the Corner Hook - Left (G) and Corner Hook - Right (H) to both the Side Rail - Left and Side Rail - Right using Bolt (A), Spring Washer (E), and Flat Washer (F).
2. Ensure the hooks are securely fastened at both ends of each side rail.

2. Attach and Secure Bolts for Hooks

1. To attach the Headboard (1) and Footboard (2) to the Side Rails first attach a Bolt (A), Spring Washer (E), and Flat Washer (F).
2. Ensure each bolt is tightened securely, maintaining a 10mm gap as shown.

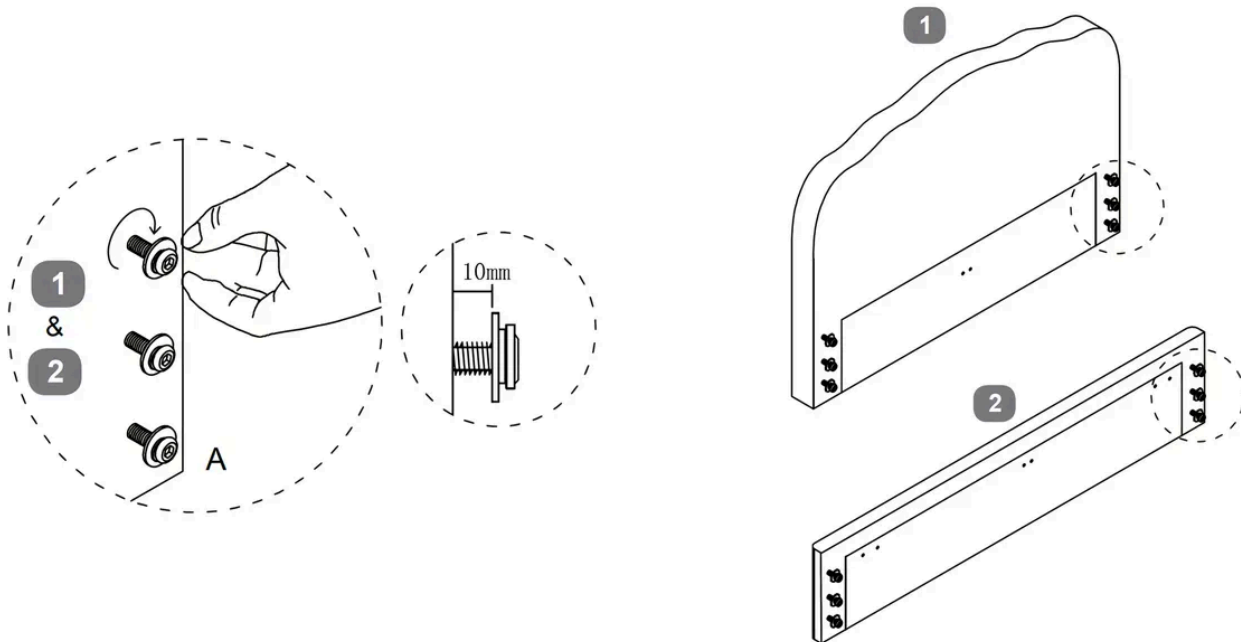

3. Assemble Bed Frame

1. Attach the Side Rail - Left (3) and Side Rail - Right (4) to the Headboard (1) and Footboard (2) using the Corner Hooks.
2. Ensure the bolts are tightened to a 90% tightness, maintaining a 10mm gap as shown.
3. Once hooked, tighten the bolts.

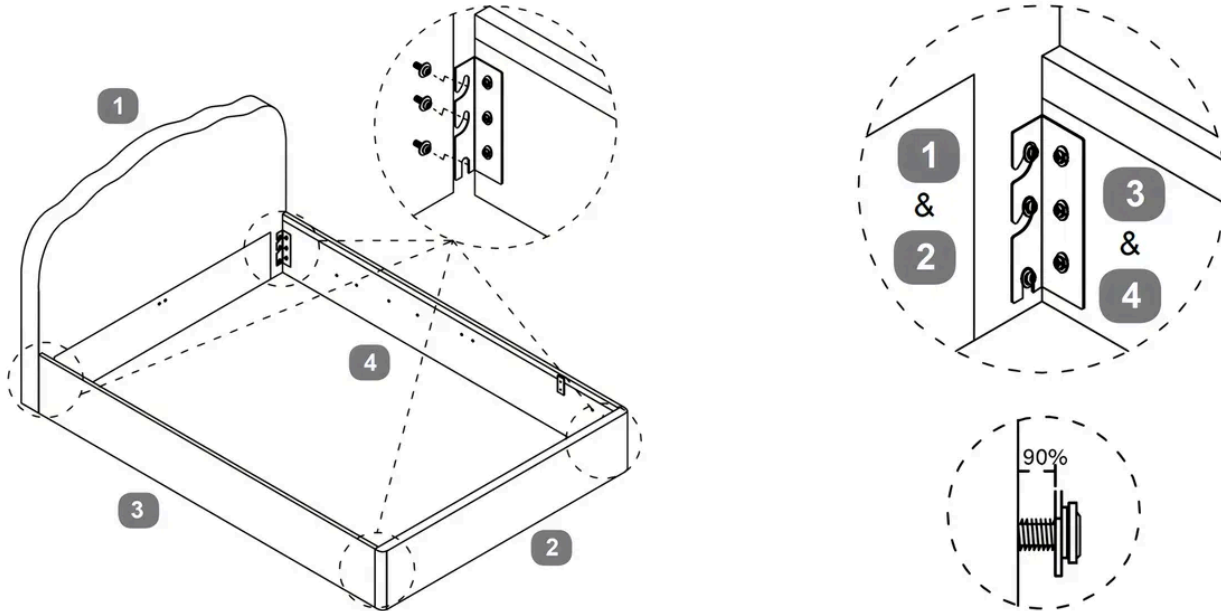

4. Install 'L' Shape Bracket

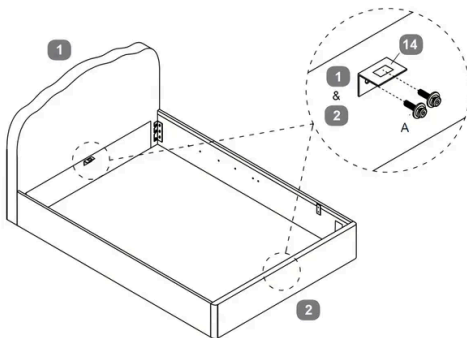

1. Attach the 'L' Shape Bracket (14) to the Headboard (1) and Footboard (2) using Bolt (A), Spring Washer (E), and Flat Washer (F).
2. Ensure the brackets are securely fastened to provide additional support to the frame.



5. Install Angled Corner Brackets

1. Attach the Angled Corner Bracket (9) to the junction of the Side Rail - Left (3), Side Rail - Right (4), and Footboard (2)
2. Use Bolt (A), Spring Washer (E), and Flat Washer (F) and tighten.
3. Ensure the brackets are aligned correctly to maintain a rectangular frame shape, as shown in the correct alignment diagram.

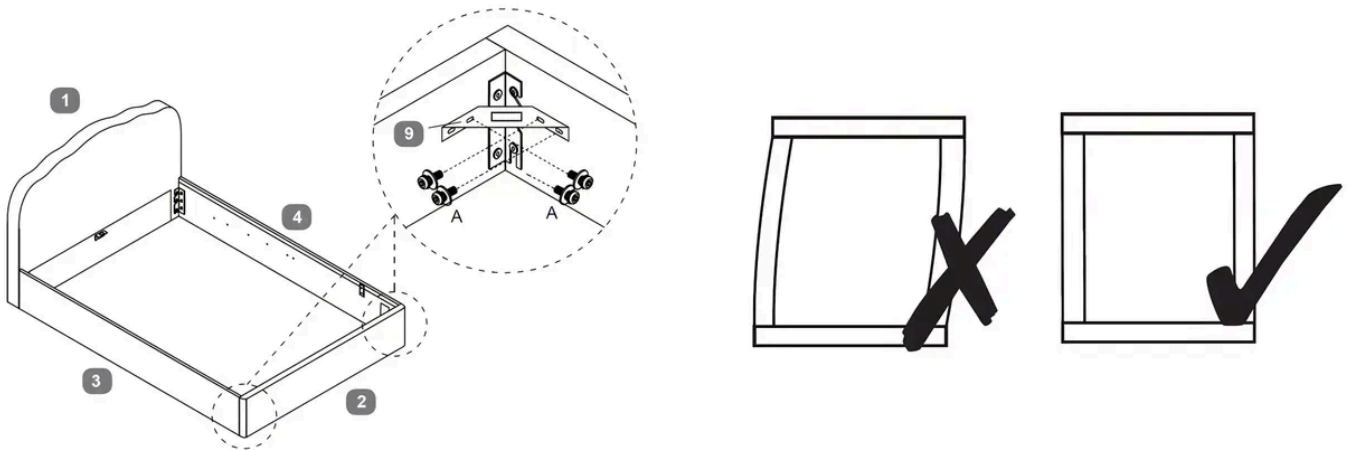

6. Attach and Secure Lift Mechanisms

1. Position the Gas-lift Mechanism LH (5) and RH (6) together with the Spacer Rails (7) inside the bed frame, along the inner Side Rails.
2. **Place the Spacer Rails (7) between the bed frame and the lift mechanism brackets, ensuring they sit underneath the gas-lift arms.**
3. Align the lower sections of the lift arms and the Spacer Rails with the pre-drilled holes on the Side Rail LH (3) and RH (4).
4. Secure each bracket with 4 × Bolt (B) on each side.
5. Tighten all bolts using the Allen Key (M) to ensure the lift arms and Spacer Rails are securely attached.

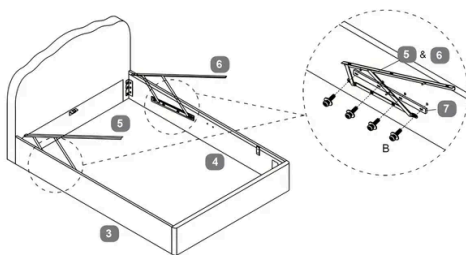

7. Install and Secure Cross Bar

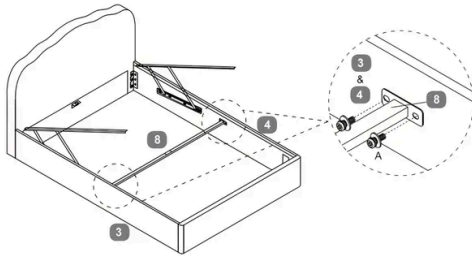

1. Attach the Side Rail Cross Bar (8) between the Side Rail - Left (3) and Side Rail - Right (4).
2. Use Bolt (A), Spring Washer (E), and Flat Washer (F) to secure the cross bar.
3. Ensure the cross bar is aligned correctly and all bolts are tightened securely for stability.

8. Install Fabric Base Cover

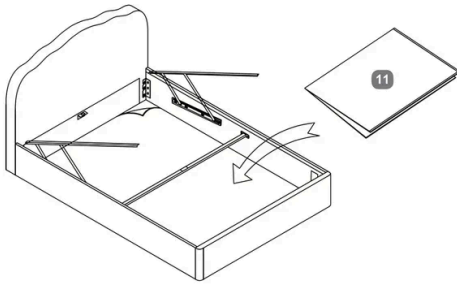

Place the Fabric Base Cover (11) inside the bed frame, ensuring it lies flat and covers the entire base area.

Adjust as necessary to fit securely within the frame.

9. Frame Alignment and Securing

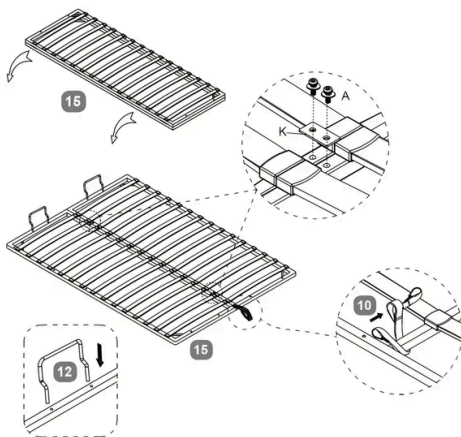

1. Unfold the Metal Slat Frame (15).
2. Align the Metal Connection Plates (K) with the pre-drilled holes on the slat frame.
3. Secure the connection plates using Bolt (A) and tighten with the Allen Key (I).
4. Attach the Mattress Stopper (12) to the end of the slat frame by inserting it into the designated slots.
5. Finish by tying the Fabric Handle Strap (10) on the opposite side.
6. Ensure all components are securely fastened and aligned properly.



10. Piston Attachment and Alignment

1. Slide the Gas-lift Piston Stem (X) onto the Axle (Y).
2. Place the Flanged Lock-Nut (D) onto the stem and tighten with the Spanner (J).
 - Do not over-tighten, leave a small gap so the stem can move freely.
3. Connect the Gas-lift Piston (13) to the pre-installed Gas-lift Mechanism on both sides of the bed frame.
4. Check that the pistons move freely and that all components are aligned and securely fastened.

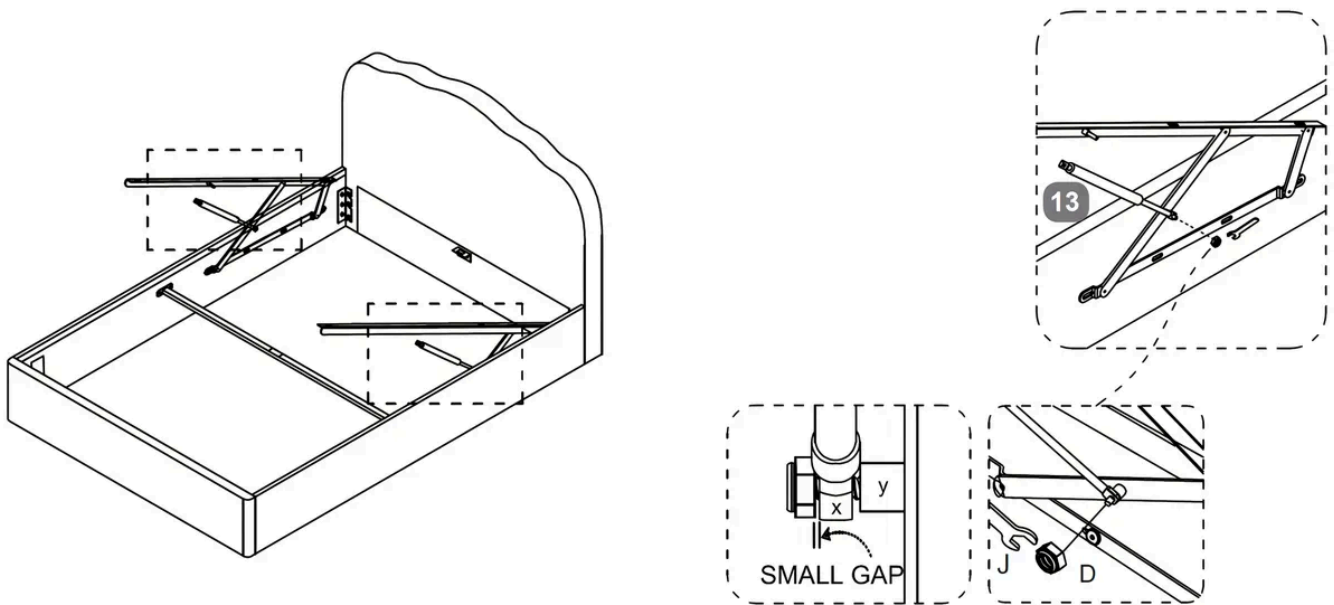

11. Secure the Metal Slat Frame

1. Align the Metal Slat Frame (15) with the Gas-lift Mechanism on both sides of the bed.
2. Loosely fit three bolt sets (Bolt C, Flat Washer F, Spring Washer E, and Flanged Lock-Nut D) on each side.
3. Carefully hold the frame down and adjust so there are even gaps on both sides.
4. Once aligned, tighten all bolts 100% using the Allen Key (I) and Spanner (J).
5. Verify that the frame is securely attached and all components are properly fastened.

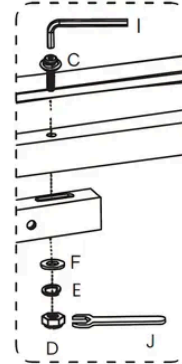
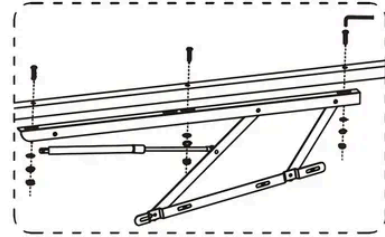
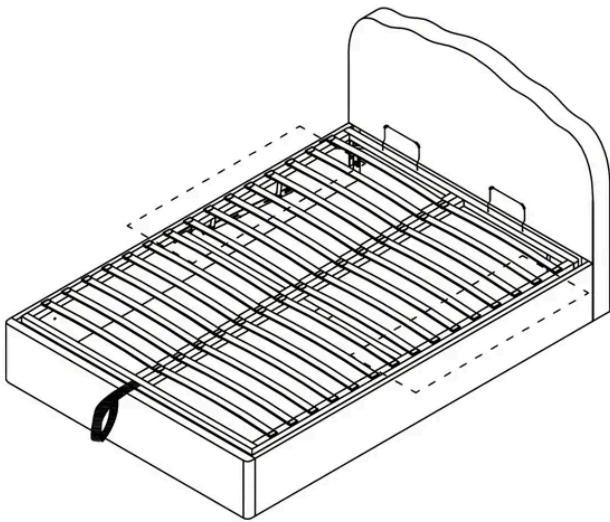

12. Secure the Gas-Lift Pistons to the Slat Frame

1. Slide the stem of the Gas-lift Piston (13) (X) onto the Axle (Y) on the underside of the Metal Slat Frame (15).
2. Fit the Flanged Lock-Nut (D) and tighten it using the Spanner (J), do not over-tighten.
3. Repeat this process for both pistons.

Important: A small gap must be left between the piston stem and the bracket to ensure the piston can move freely. Refer to the diagram to confirm correct spacing.

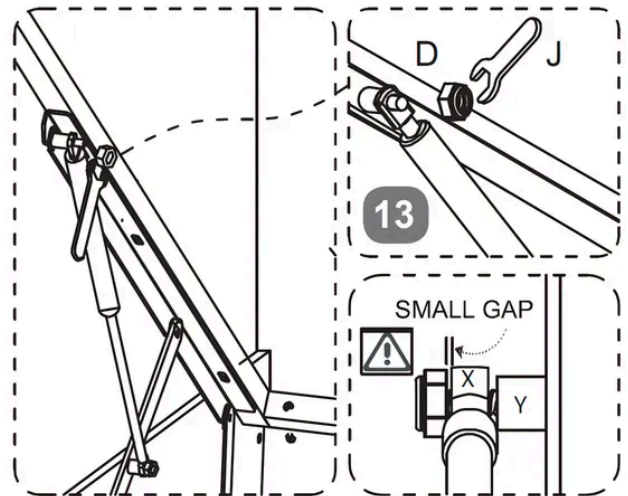
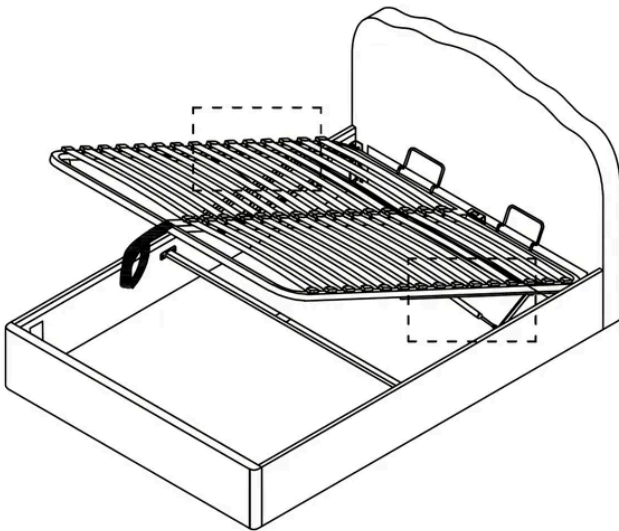

13. Final Checks and Safety Precautions

1. Storage Area Safety

- Ensure the ottoman is fully open before accessing the storage space.
- Avoid reaching through the hinge area to prevent injury.
- Keep children and pets away from the bed when it is open.
- Do not stand or climb inside the internal storage compartment.
- Regularly inspect the bed mechanism to ensure it is functioning safely and smoothly.

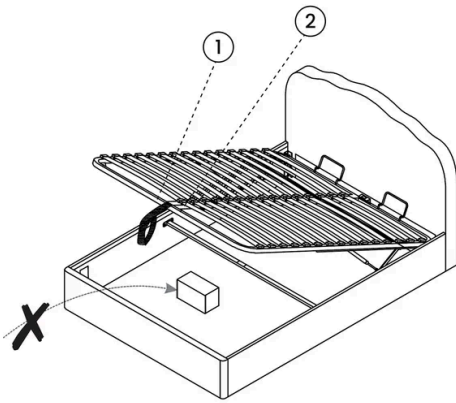

2. Operating Instructions

- The gas-lift mechanism is intended for adult use only. It is not suitable for users under 12 years old.
- Always lift and lower the ottoman with the mattress in place, using the fabric hand strap (13) to raise and lower the base.
- Keep hands and body clear of the lifting mechanism during operation to avoid entrapment.

Note: Be mindful of what you store under the bed. Items such as suitcases or boxes must not touch the underside of the slat frame, as this may cause damage.

Maximum recommended storage height is 225mm.



Instructions by Time4Sleep Products

Sophia Pink Ottoman Bed Frame