

# ASSEMBLY INSTRUCTION FOR WC 3-7480L-WSR-BW-75"

**Note:**  
 ■ Read instructions carefully.  
 ■ Carefully identify each component especially those that are similar.  
 ■ Separate and identify each component from the hardware pack and rest each one in its proper location before fastening.  
 ■ Do not over tighten the screws or bolts when assembling.

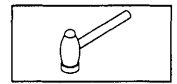

## TOOL REQUIRED



### Step 1

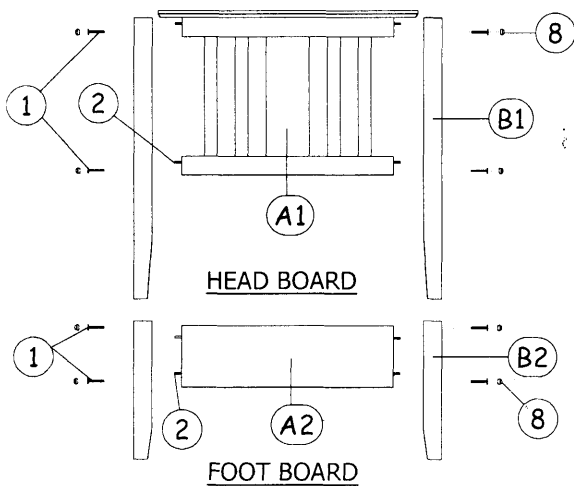

Assemble the bed frame component as shown.

### Step 4

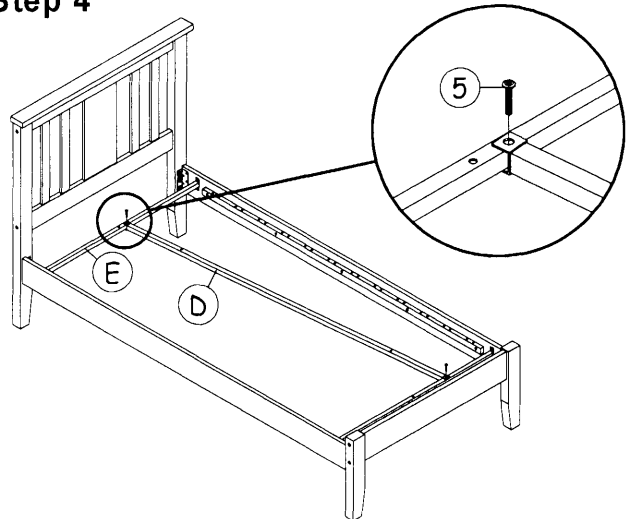

Fix center bar 'D' to the cross bar 'E' with bolt '5' as shown.

### Step 2

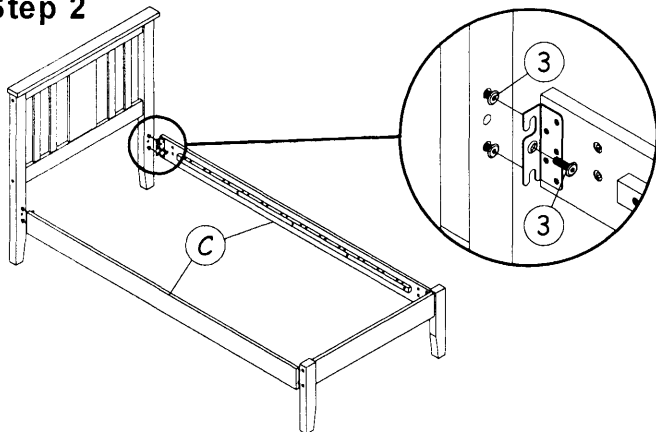

Fix bolt '3' (upper & lower bolts) into position on wood post as shown. After that, hook the side rail to the bolt and fix center bolts '3' as shown.

**Important note : Do not tighten the bolts yet!**

### Step 5

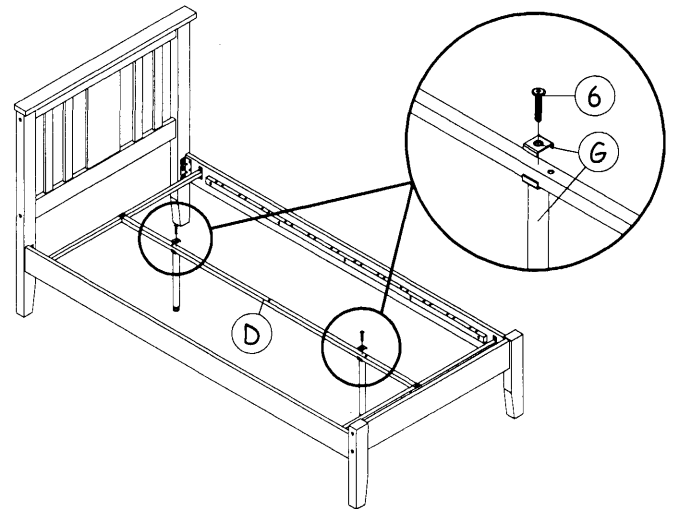

Fix bed support legs as shown.

### Step 3

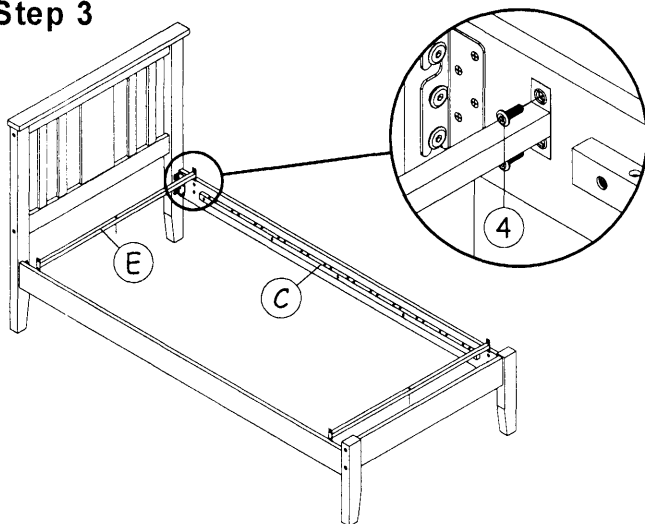

Fix cross bar 'E' to the side rail with bolts '4' as shown.



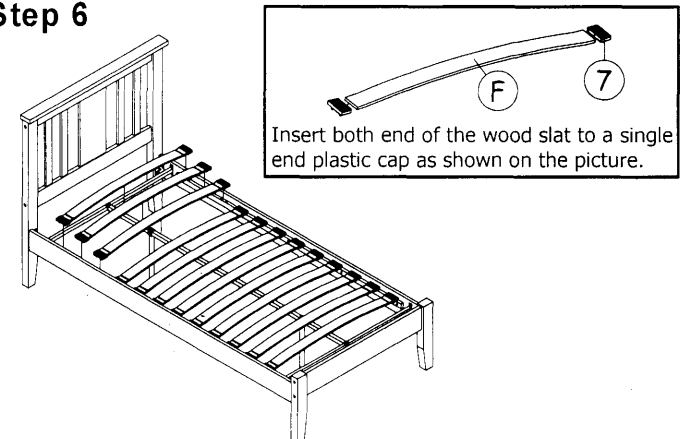







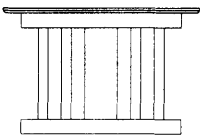



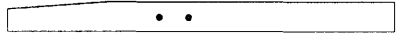

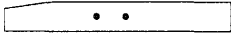
### Step 6

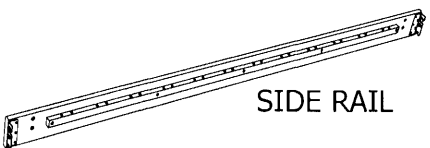

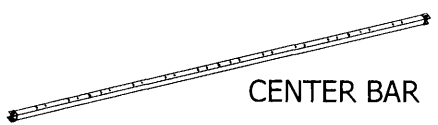
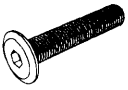
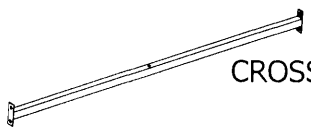
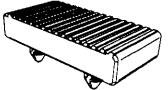
Once wood slats have been inserted into the plastic caps, fix one end of wood slat into the hole of side rail by pressing it accordingly to the defaults holes and the other end to the other side rail holes. Ensure the plastic cap's pin aimed to the hole.

**Please follow our assembly instruction procedure for easier assemble.**

# HARDWARE & PART LIST FOR WC 3-7480L-WSR-BW-75"

NO.	PART	QTY.	NO.	HARDWARE	QTY.
A	 <div style="display: inline-block; vertical-align: middle;"> <div style="border: 1px solid black; padding: 2px; display: inline-block; margin-right: 5px;">1</div> HEAD FRAME                 </div>	1 PC	1	 <div style="display: inline-block; vertical-align: middle;">                     JCBC BOLT M6 x 80mm                 </div>	8 PCS
	 <div style="display: inline-block; vertical-align: middle;"> <div style="border: 1px solid black; padding: 2px; display: inline-block; margin-right: 5px;">2</div> FOOT FRAME                 </div>	1 PC	2	 <div style="display: inline-block; vertical-align: middle;">                     WOOD DOWEL M8 x 30mm                 </div>	8 PCS
B	 <div style="display: inline-block; vertical-align: middle;"> <div style="border: 1px solid black; padding: 2px; display: inline-block; margin-right: 5px;">1</div> HEAD WOOD POST L/R                 </div>	2 PCS	3	 <div style="display: inline-block; vertical-align: middle;">                     JCBC BOLT M8 x 25mm                 </div>	12 PCS
	 <div style="display: inline-block; vertical-align: middle;"> <div style="border: 1px solid black; padding: 2px; display: inline-block; margin-right: 5px;">2</div> FOOT WOOD POST L/R                 </div>	2 PCS	4	 <div style="display: inline-block; vertical-align: middle;">                     JCBC BOLT M6 x 15mm                 </div>	8 PCS
C	 <div style="display: inline-block; vertical-align: middle;">                     SIDE RAIL                 </div>	2 PCS	5	 <div style="display: inline-block; vertical-align: middle;">                     JCBC BOLT M6 x 30mm                 </div>	2 PCS
D	 <div style="display: inline-block; vertical-align: middle;">                     CENTER BAR                 </div>	1 PC	6	 <div style="display: inline-block; vertical-align: middle;">                     JCBC BOLT M8 x 40mm (ASSEMBLED)                 </div>	2 PCS
E	 <div style="display: inline-block; vertical-align: middle;">                     CROSS BAR                 </div>	2 PCS	7	 <div style="display: inline-block; vertical-align: middle;">                     SINGLE END PLASTIC CAP                 </div>	24 PCS
F	 <div style="display: inline-block; vertical-align: middle;">                     WOOD SLAT                 </div>	12 PCS	8	 <div style="display: inline-block; vertical-align: middle;">                     WOOD BUTTON                 </div>	8 PCS
G	 <div style="display: inline-block; vertical-align: middle;">                     SUPPORT LEG                 </div>	2 PCS	9	 <div style="display: inline-block; vertical-align: middle;">                     ALLEN KEY - M6                 </div>	1 PC
			10	 <div style="display: inline-block; vertical-align: middle;">                     ALLEN KEY - M8                 </div>	1 PC